

PFC1729

Automatic Power Factor Correction Relay

This document contains the latest technical information about Automatic Power Factor Correction Relay (PFC1729) which is a micro-controller based KVAR controller. The unit is tested against latest "MTE" Standard Model PRS400.3 having basic accuracy of 0.02%, traceable up to International Standards derived using appropriate ratio techniques.

The product, PFC1729 is sophisticated electronic equipment and the user is advised to read this User's Manual carefully before attempting to install or operate the equipment.

Published on: 08.06.2018

Document Version: 1.0

Warranty Statement

Trinity warrants to the original retail purchaser of the Trinity product enclosed with this limited warranty statement that the product, if purchased new and used in the India conforms to the manufacturer's specifications and will be free from defects in workmanship and materials for a period of one year from the date of original purchase, unless expressly stated otherwise by Trinity, in a written format.

Should your Trinity product prove defective during the warranty period, please bring the product securely packaged in its original container or an equivalent, along with proof of the date of original purchase, to our Trinity Dealer or Factory. You are responsible for all costs (shipping, insurance, travel time) in getting the product to the service location. Trinity will, at its option, repair or replace on an exchange basis the defective unit, without charge for parts or labor. When warranty service involves the exchange of the product or of a part, the item replaced becomes Trinity property. The replacement unit may be new or refurbished to the Trinity standard of quality, and at Trinity's option, the replacement may be another model of like kind and quality. Trinity's liability for replacement of the covered product will not exceed the original retail selling price of the covered product. Exchange or replacement products or parts assume the remaining warranty period of the product covered by this limited warranty.

What This Warranty Does Not Cover:

This warranty does not apply to refurbished or reconditioned products. This warranty covers only normal use in India. This warranty does not cover damage to the Trinity product caused by parts or supplies not manufactured, distributed or

certified by Trinity. This warranty is not transferable. This warranty does not cover third party parts, components or peripheral devices added to the Trinity product after its shipment from Trinity. Trinity is not responsible for warranty service should the Trinity label or logo or the rating label or serial number be removed or should the product fail to be properly maintained or fail to function properly as a result of misuse, abuse, improper installation, neglect, improper shipping, damage caused by disasters such as fire, flood, and lightning, improper electrical current, interaction with non-Trinity products or service other than by an Trinity Authorized Service.

The warranty and remedy provided above are exclusive and in lieu of all other express or implied warranties including, but not limited to, the implied warranties of merchantability or fitness for a particular purpose. In the event, the remedies above fail, Trinity's entire liability shall be limited to a refund of the price paid for the Trinity product covered by this limited warranty. Except as provided in this written warranty, neither Trinity Energy Systems Pvt. Ltd. nor its affiliates shall be liable for any loss, inconvenience, or damage, including direct, special, incidental, or consequential damages, resulting from the use or inability to use the Trinity product, whether resulting from breach of warranty or any other legal theory.

Contents

Introduction	6
System Consideration	6
Main Features	7
Technical Specifications	9
Installation and Commissioning	11
Connection Scheme	13
Capacitor Panel	14
Operational Details	15
Programming Mode	16
1. Setting the Main CT-Primary	18
2. Setting the CT-Secondary	19
3. Setting the Capacitor CT enable/disable	20
4. Setting the Capacitor CT-Primary	21
5. Setting the mode of control action.....	21
6. Setting the Desired PF	22
7. Setting the Time Delay in between stages	23
8. Setting On Delay with Lagging PF	24
9. Setting Off Delay with Leading PF.....	25
10. Setting Damp Factor for Sensitivity of Control Action	26
11. Selecting Capacitor Bank Size	27
12. Selecting Switching Action.....	28
13. Selecting Minimum Bank Value (VAR mode only)	29
14. Performing Autosense of Capacitor Bank Size (VAR mode only)	30
15. Setting Over Volt Tripping Enable	31
16. Selecting Over Volt Tripping Value	32

17.	Setting Under Volt Tripping Enable	33
18.	Selecting Under Volt Tripping Value	34
19.	Selecting Installation	35
20.	Selecting Phase compensation Value	36
21.	Setting Alarm for Over Compensation	37
22.	Setting Alarm for Under Compensation	38
23.	Setting Hysteresis Value of Voltage.....	39
24.	Setting New Password	40
25.	Setting Manual banks (Manual mode only).....	41
	Run Mode.....	43
	Screen Display	43
	ALARM Functionality	43
	TRIP Functionality	44
	Manual/Auto Mode	46
	Control Outputs	46
	(A) Trouble Shooting	47
	(B) Trouble Shooting Guide	50

Introduction

The relay is meant for flush mounting in a panel for connection to the electrical system.

The relay is the 'intelligence' which controls the automatic system for correction of the power factor. It senses the power factor by taking the ratio of the KW and the true rms KVA of the system, for any phase to neutral or phase to phase connections of the three phase electrical system. This means that phase to neutral or phase to phase are connected to the meter as voltage inputs and current of the same phase or different phase as current input. For correct operation of the relay, however there are some minimum requirements should be met. Unless the various points in the system which are mentioned below are correctly setup, proper operation of the relay cannot be expected.

System Consideration

1. If there is an imbalance in the three phase currents, the current transformer (CT) must be mounted on the phase which has maximum load. Entire load current and the capacitor current must pass through the bus on which the main CT is mounted. Ensure that this condition is achieved for proper operation of relay.
2. The actual load current at the time of operation should be more than 5% of the CT Primary current rating. If this is not true, the relay will not operate.
3. The relay assumes a uniform loading of the three phase system. If all capacitor banks are off and the relay indicates LEAD power factor, then the Main CT S1 and S2 must be interchanged so as to correct the polarity error.
4. The relay senses the power factor and switches ON or OFF the capacitor banks (through contactors in a panel), to bring power factor closest to the set

value. For this the voltage must be within plus/minus 20% of the rated voltage of the relay.

5. If need is felt for an external auto/manual control, there is no harm in having one, provided it is implemented properly. An improperly implemented scheme might cause the mal-operation of the panel. Make sure this is not the case before putting the blame on the relay.
6. Check all these points carefully in the system. If found ok, installation and commissioning of the relay is easy.

Main Features

- All readings are true RMS measurements
- Site selectable 1A or 5A CT secondary
- Automatic power factor control through system PF.
- Programmable target PF setting (from 0.800 to 1.000 LAG or LEAD)
- Programmable Time delay for step switching (Normal: 40-300, Fast: 1-10 Sec)
- Stage wise LED indication
- Auto/Manual mode selection through programming mode
- Normal/Fast switching control action is site programmable
- Alarm and tripping indication for over/under compensation and over/under voltage respectively
- Installation selection for phase to phase(L-L) or phase to neutral(L-N) input is site selectable
- Control action with/without capacitor CT is site selectable
- Switch ON/OFF banks manually in manual mode only



Technical Specifications

Parameters		
Type	Name	Statistics
INPUT	Power Supply	Auxiliary Supply : 80 - 500 VAC, 50-60 Hz.
	Voltage	Direct Voltage Input : 50-300V L-N & 50-500V L-L Burden : 0.5VA
	Current	Secondary Current Input : 5A or 1A (Site Selectable) CT Ratio : Site Selectable Range of Reading : 5 - 9995A Burden : < 1.0VA Overload : 5A CT = 6A RMS Continuous 1A CT = 1.2A RMS Continuous
OUTPUT	Relay	Switching Voltage : Max. 230 VAC Switching Power : Max. 1000W Expected Mechanical life : >10 x 10 ⁶ switching operations Expected Electrical life : >4 x 10 ⁶ switching operations @ (Load = 200VA, Cosφ=0.5)
		[9]

MEASUREMENT	True RMS Basic Parameters	Capacitor Current	CT Primary : Site Selectable Range of reading : 5 – 9995A Accuracy : 1.0% of Reading
		Power Factor	Accuracy : 1.0% of Reading (IPFI \geq 0.5) Range of reading : 0.05 to 1.00 Lag/Lead
MISCELLANEOUS	Dimensions	Bezel	144 X 144 mm
		Panel Cutout	138 X 138 mm
		Depth of installation	55 mm
		Operating temp	10°C to 50°C
		Weight	0.560 Kg. (Approx.)
		Min. Operating Current	5% of CT Primary in FIFO/SFIFO mode

Installation and Commissioning

In case of imbalanced load, the phase which has maximum load should have the main CT mounted on it. Ensure that the capacitor CT must also be mounted on its same phase for auto sense of each capacitor banks.

To install and commissioning the unit, proceed as follows:

1. Push the unit into the panel and mount it by using the clamps provided.
2. Connect the Auxiliary supply (80V AC to 500V AC) to the terminals marked P and N on the unit.
3. Connect Phase to Neutral or Phase to Phase to the terminals marked U1 and U2 on the unit. Make sure you have to select installation and phase compensation values respective to this connection. For this refer Programming Mode chapter. Make sure that the phase coming to the unit comes through control fuse of 1.0 amp rating. This will protect the electronics inside from damage due to severe over voltages or phase faults in the system.
4. Connect the two wires from main CT to terminal marked M and L such that S1 from CT goes to M and S2 from CT goes to L on the unit.
5. Connect the two wires from the capacitor CT to terminal marked CM and CL on the unit. Note: The capacitor CT is needed for operation in VAR mode only and use of capacitor CT is optional. In FIFO and SFIFO mode, the capacitor CT is not needed.
6. Switch on three phase supply. The unit will display some information for few seconds.

7. First of all, user should program all the parameters of the unit as required. The proper operation of the relay can commence only after these parameters are defined.
In case of autosense, the unit switches one bank on at a time and also displays the bank size of every stage. After completing, the unit will restart and enter into run mode.
8. Now, the unit is ready for operation.

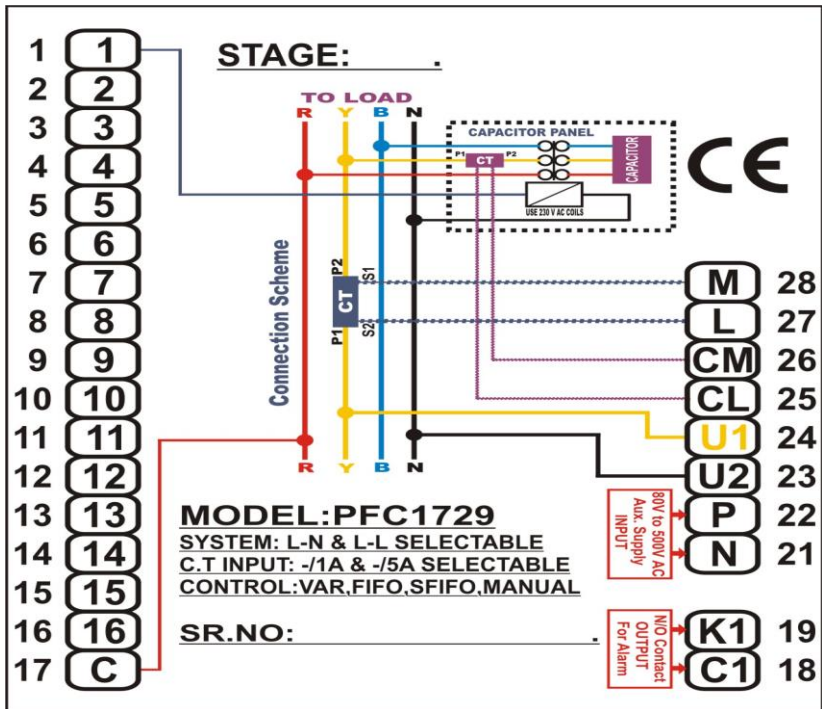

Connection Scheme

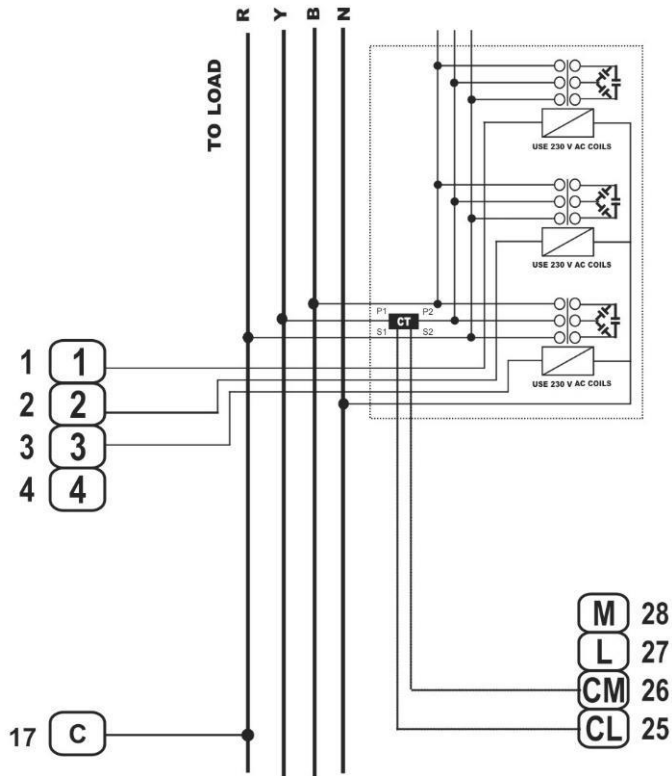

Capacitor Panel

Operational Details

The KVAR based controller PFC1729 is a versatile unit, with all the features needed to implement a robust PF maintenance system.

There are basically two modes of operation in PFC1729:

1. Programming Mode
2. Run Mode

After supplying power (80 VAC - 500 VAC), the unit displays the power on message, TSPL and also display some useful information by default and then comes into Run Mode as shown below.

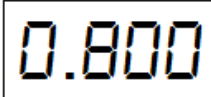
 For Lag

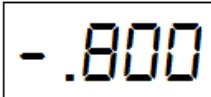
 For Lead

The unit can now be operated by using the following keys for both the Programming Mode and Run Mode:



Programming Mode







To make the unit suitable for most field conditions and different types of loads, a lot of parameters have been made programmable. The following parameters can be programmed by the user:

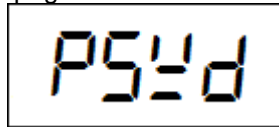





1. CT Primary
2. CT Secondary.
3. Capacitor CT Primary enable/disable.
4. Capacitor CT Primary.
5. Mode of control action FIFO/VAR/SFIFO/MANUAL
6. Desired PF setting
7. Time Delay - delay between two successive switching operations of the relay
8. On Delay for lagging PF.
9. Off Delay for leading PF.
10. Damp Factor for sensitivity of the control action.
11. Capacitor Bank stages.
12. Switching action Fast or Normal.
13. Control action sensitivity in percentage - (75% or 100%).
14. Autosense of capacitor bank sizes.

15. Over voltage enable/disable.
16. Set over Voltage value if it is enabled.
17. Under voltage enable/disable.
18. Set under voltage value if enabled.
19. Installation selection for L-L or L-N input connection.
20. Phase compensation value as per network selection.
21. Over compensation enable/disable.
22. Under compensation enable/disable.
23. Hysteresis voltage in percentage (%) for under and over voltage value.
24. New password setting.
25. Manually switch ON/OFF banks if manual mode is selected.

To enter in programming mode, press  for about five seconds continuously. The display will prompt below page.



Now press  and 1st digit of password will start blinking. Now for example if your password is “1234”, set 1st digit’s value to “1” by using  and  key and then press . Now 2nd digit of password will start blinking. Set its value to “2” by using  and  key and press . Now 3rd digit of password will start blinking. Set its

value to “3” by using  and  key and press . Now 4th digit of password will start blinking. Set its value “4” by using  and  key and press . **Note: if you enter wrong password it will display “Err” for approx 3 seconds and enter into run mode.**

Once you enter proper password value, it will enter into programming mode and you can set other parameters as required for proper control action.





1. Setting the Main CT-Primary

In order to give actual current values in your system, the Main CT Ratio between the primary and secondary current should be set. The CT primary can be set from 5A to 9995A.

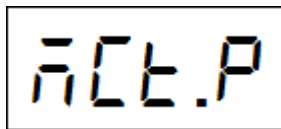
To set the Main CT Primary, proceed as follows:

1. In the Run Mode display, press  for five seconds continuously and enter password.
2. The display will now prompt:





3. Press  key. Now it will show its value. Set its value by pressing  and  keys until the desired value is reached and then press  key to confirm the value. Now it will show next parameter. Once you change all the required parameters, press key  for five seconds to

come out from programming mode. If any parameter is changed, unit will restart.





2. Setting the CT-Secondary

In order to give actual current values in your system, the Main CT Ratio between the primary and secondary current should be set. The CT secondary can be set to 1 or 5.

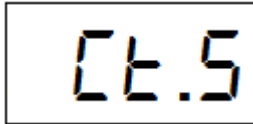
To set the CT secondary, proceed as follows:

1. In the Run Mode display, press  for five seconds continuously and enter password.
2. Press  key till the following prompt is seen:





3. Press  key. Now it will show its value. Set its value by pressing  and  keys until the desired value is reached and then press  key to confirm the value. Now it will show next parameter. Once you change all the required parameters, press key  for five seconds to come out from programming mode. If any parameter is changed, unit will restart.





3. Setting the Capacitor CT enable/disable

In VAR control action mode, using capacitor CT, proper Bank KVAR can be sensed.

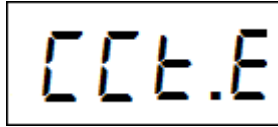
To enable or disable it, proceed as follows:

1. In the Run Mode display, press  for five seconds continuously and enter password.
2. Press  key till the following prompt is seen:





3. Press  key. Select display prompt to “YES” or “nO” by pressing  and  keys and then press  key to confirm the setting. Now it will show next parameter. Once you change all the required parameters, press key  for five seconds to come out from programming mode. If any parameter is changed, unit will restart.

NOTE: In case of Capacitor CT disabled, PFC1729 can also sense bank size in Autosense mode. But, here load must be stable during Autosense process to sense proper Capacitor Bank size.

4. Setting the Capacitor CT-Primary



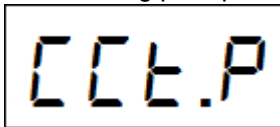

In order to sense proper capacitor KVAR based on capacitor CT, the capacitor CT Primary should be set. The capacitor CT primary can be set from 5A to 9995A.

To set the capacitor CT primary, proceed as follows

1. In the Run Mode display, press  for five seconds continuously and enter password.
2. Press  key till the following prompt is seen:



The image shows a rectangular LCD display with the text 'CCT.P' in a large, pixelated font. The 'C' and 'T' are slightly larger than the 'C' and 'P'. The 'P' has a period below it. The display is enclosed in a thin black border.



3. Press  key. Now it will show its value. Set its value by pressing  and  keys until the desired value is reached and then press  key to confirm the value. Now it will show next parameter. Once you change all the required parameters, press key  for five seconds to come out from programming mode. If any parameter is changed, unit will restart.

5. Setting the mode of control action





For PF correction, there are four types of Control Action such as FIFO, VAR, SFIFO and Manual, which are selectable at site. In case the control action is selected to VAR, Minimum Bank, Capacitor CT and AUTOSENSING become relevant as programmable parameters.

However, these parameters are not applicable in case of FIFO, SFIFO and Manual mode control action.

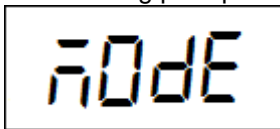
To select the mode of control action, proceed as follows:

1. In the Run Mode display, press  for five seconds continuously and enter password.
2. Press  key till the following prompt is seen:





3. Press  key. Select the control action mode to “VAR”, “FIFO”, “SFIF” or “MANL” by pressing  and  keys and then press  key to confirm the setting. Now it will show next parameter. Once you change all the required parameters, press key  for five seconds to come out from programming mode. If any parameter is changed, unit will restart.

6. Setting the Desired PF



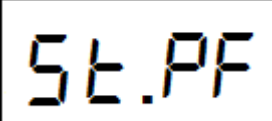

The desired PF can be set to either LEAD or LAG according to user's requirement. For FIFO and SFIFO mode of control action, the PF can be set from 0.800 LAG to 1.000 LAG. For VAR mode of control action, the PF can be set to either LEAD or LAG. In case of LAG, the PF could be set from 0.800 to 1.000. In case of LEAD, the PF could be set from 1.000 to 1.800. e.g., the PF to be set for 0.998 LEAD should be set as 1.998.

To set the desired PF, proceed as follows:

1. In the Run Mode display, press  for five seconds continuously and enter password.
2. Press  key till the following prompt is seen:





56.PF

3. Press  key. Now it will show its value. Set its value by pressing  and  keys until the desired value is reached and then press  key to confirm the value. Now it will show next parameter. Once you change all the required parameters, press key  for five seconds to come out from programming mode. If any parameter is changed, unit will restart.





7. Setting the Time Delay in between stages

The Time Delay is freely programmable. In Fast switching mode, its value can be set from 1 to 10 seconds. In Normal switching mode, its value can be set from 40 to 300 seconds. For the user defined time delay, the relay will not switch on or off for any capacitor bank. i.e. Unit will not take control action for PF correction. This is one type of a digital dead band.

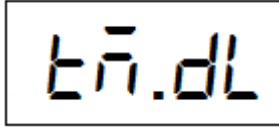
To set the Time Delay, proceed as follows:

1. In the Run Mode display, press  for five seconds continuously and enter password.
2. Press  key till the following prompt is seen:



3. Press  key. Now it will show its value. Set its value by pressing  and  keys until the desired value is reached and then press  key to confirm the value. Now it will show next parameter. Once you change all the required parameters, press key  for five seconds to come out from programming mode. If any parameter is changed, unit will restart.



8. Setting On Delay with Lagging PF

In case of FIFO and SFIFO mode of control action, On Delay is freely programmable. In Fast switching mode, its value can be set from 1 to 10 seconds. In Normal switching mode, its value can be set from 10 to 300 seconds. If the system PF falls below the target PF on the lagging side, the unit waits for the situation to persist for the programmed On Delay seconds. If the situation remains the same, the relay will switch ON the next capacitor bank. However, during the On Delay period if the target PF gets achieved or overshoot, the On Delay is reset and the monitoring of PF value for sake of control action begins afresh.

In other words, if the PF keeps lagging below the set target PF value continuously for On Delay seconds, then only the next capacitor bank will Switch ON.



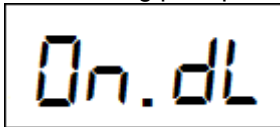

This ON delay will apply only in the FIFO or SFIFO control action mode. In case the control action has been selected as VAR, only Time Delay and Damp value will apply.

To set the On Delay, proceed as follows:

1. In the Run Mode display, press  for five seconds continuously and enter password.
2. Press  key till the following prompt is seen:



The image shows a rectangular LCD display with the text "On.dL" in a digital font. The "On" is in a larger font size than ".dL".

3. Press  key. Now it will show its value. Set its value by pressing  and  keys until the desired value is reached and then press  key to confirm the value. Now it will show next parameter. Once you change all the required parameters, press key  for five seconds to come out from programming mode. If any parameter is changed, unit will restart.



9. Setting Off Delay with Leading PF

Off Delay is freely programmable. In Fast switching mode, its value can be set from 1 to 10 seconds. In Normal switching mode, its value can be set

from 10 to 300 seconds. If the system PF falls on the lead side hence capacitor banks have to be switched off, the relay will ensure that the situation prevails continuously for off delay seconds, and only then takes the control action.



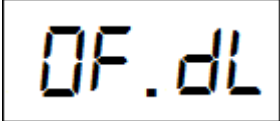

This parameter will not apply if the control action selected is VAR mode.

To set the Off Delay, proceed as follows:

1. In the Run Mode display, press  for five seconds continuously and enter password.
2. Press  key till the following prompt is seen:



The image shows a rectangular LCD display with a black border. Inside the display, the text 'OF.dL' is shown in a digital, seven-segment font. 'OF' is in a larger font size than '.dL'.



3. Press  key. Now it will show its value. Set its value by pressing  and  keys until the desired value is reached and then press  key to confirm the value. Now it will show next parameter. Once you change all the required parameters, press key  for five seconds to come out from programming mode. If any parameter is changed, unit will restart.

10. Setting Damp Factor for Sensitivity of Control Action





The Damp is freely programmable. In fast switching mode, its value can be set from 1 to 10 seconds. In Normal switching mode, its value can be set from 5 to 300 seconds so as to slow down the response of the control

algorithm. Setting a higher value of DAMP will slow down the response of the relay to transient jumps into system KVAR values. This parameter is applicable in VAR mode only.

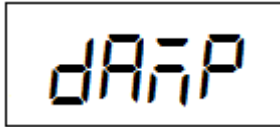
To set the Damp Factor, proceed as follows:

1. In the Run Mode display, press  for five seconds continuously and enter password.
2. Press  key till the following prompt is seen:





3. Press  key. Now it will show its value. Set its value by pressing  and  keys until the desired value is reached and then press  key to confirm the value. Now it will show next parameter. Once you change all the required parameters, press key  for five seconds to come out from programming mode. If any parameter is changed, unit will restart.





11. Selecting Capacitor Bank Size

PFC1729 supports up to 16 capacitor bank stages. For user's system requirement, the number of active stages can be selected from 2 to 16. This is helpful in cases where the relay has been purchased for higher number of stages but presently, fewer stages have been actually connected.

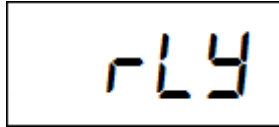
To select the relays, proceed as follows:

1. In the Run Mode display, press  for five seconds continuously and enter password.
2. Press  key till the following prompt is seen:



3. Press  key. Now it will show its value. Set its value by pressing  and  keys until the desired value is reached and then press  key to confirm the value. Now it will show next parameter. Once you change all the required parameters, press key  for five seconds to come out from programming mode. If any parameter is changed, unit will restart.

NOTE: It is recommended to do autosensing if Relays value is changed.

12. Selecting Switching Action

Normal (Contactor) OR Fast (Thyristor) switching action is site selectable. Depends on switching action selection, value of Time delay, On delay, Off delay and Damp should be changed.



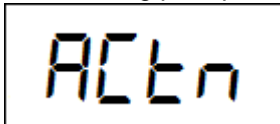

To select switching action, proceed as follows:

1. In the Run Mode display, press  for five seconds continuously and enter password.

2. Press  key till the following prompt is seen:



Actn



3. Press  key. Select display prompt to “tHYr” (Fast) or “COnt” (Normal) by pressing  and  keys and then press  key to confirm the setting. Now it will show next parameter. Once you change all the required parameters, press key  for five seconds to come out from programming mode. If any parameter is changed, unit will restart.

13. Selecting Minimum Bank Value (VAR mode only)

If the Minimum Bank value is set to 100%, the unit will take control action when the need KVAR (system KVAR value which calls for some control action) is greater than or equal to the minimum capacitor bank connected. E.g. if the need KVAR value is 6 KVAR and the smallest capacitor bank connected is 5 KVAR, then it will be switched ON. Alternatively, if the smallest bank is 10 KVAR, no control action will happen.



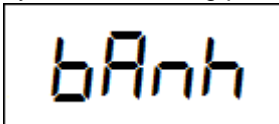

Similarly, if the Minimum bank value is set at 75%, the relay will take control action even if the need KVAR value is greater than 75% of the smallest capacitor bank connected.

To set the Minimum Bank Value, proceed as follows:

1. In the Run Mode display, press  for five seconds continuously and enter password.
2. Press  key till the following prompt is seen:



The image shows a rectangular LCD display with a black border. Inside the display, the text 'bAnh' is shown in a blue, pixelated font. The 'b' is lowercase, 'A' is uppercase, and 'nh' are lowercase.



3. Press  key. Now it will show its value. Set its value by pressing  and  keys until the desired value is reached and then press  key to confirm the value. Now it will show next parameter. Once you change all the required parameters, press key  for five seconds to come out from programming mode. If any parameter is changed, unit will restart.

14. Performing Autosense of Capacitor Bank Size (VAR mode only)

When the Autosense is set to YES, the unit switches on all relays one by one. The bank sizes will also display as capacitor banks get sensed one by one and the user therefore must be patient and wait for about 4 to 5 minutes while the autosense is in progress. This process is vital for the smooth



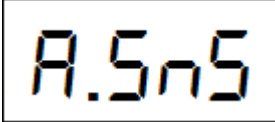

operation of the relay. Once all capacitor banks are sensed, the relay will restart and take control action as per Fast/Normal switching is selection.

To get the relay to Autosense, proceed as follows:

1. In the Run Mode display, press  for five seconds continuously and enter password.
2. Press  key till the following prompt is seen:





A.SnS

3. Press  key. Select display prompt to “YES” by pressing  and  keys and then press  key to confirm the setting.
4. If any banks are ON, first it will switch OFF those banks and then starts autosensing the capacitor stages one by one. After completing the AUTOSENSING up to the number of relays specified before, the unit will restart and enter into Run mode.





15. Setting Over Volt Tripping Enable

This setting will enable or disable over voltage tripping. If it is set to enable, user have to set value of over voltage tripping.

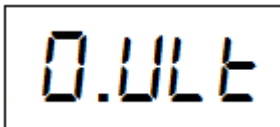
To enable or disable over voltage tripping, proceed as follows:

1. In the Run Mode display, press  for five seconds continuously and enter password.
2. Press  key till the following prompt is seen:





3. Press  key. Set display prompt to “On” or “OFF” by pressing  and  keys and then press  key to confirm the setting. Now it will show next parameter. Once you change all the required parameters, press key  for five seconds to come out from programming mode. If any parameter is changed, unit will restart.

16. Selecting Over Volt Tripping Value





If over voltage tripping is enabled, user can set over voltage tripping value. In L-L installation selection, its value can be set from 540 to 570 volts. In L-N installation selection, its value can be set from 256 to 264 volts. Read TRIP functionality for more details.

To set over voltage value, proceed as follows:

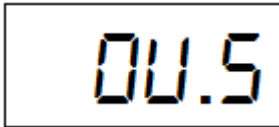
1. In the Run Mode display, press  for five seconds continuously and enter password.



2. Press  key till the following prompt is seen:







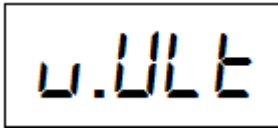

3. Press  key. Now it will show its value. Set its value by pressing  and  keys until the desired value is reached and then press  key to confirm the value. Now it will show next parameter. Once you change all the required parameters, press key  for five seconds to come out from programming mode. If any parameter is changed, unit will restart.

17. Setting Under Volt Tripping Enable

This setting will enable or disable under voltage tripping. If it is set to enable, user have to set value of under voltage tripping. To enable or disable under voltage tripping, proceed as follows:

1. In the Run Mode display, press  for five seconds continuously and enter password.
2. Press  key till the following prompt is seen:





3. Press  key. Select display prompt to “On” or “OFF” by pressing  and  keys and then press  key to confirm the setting. Now it will show next parameter. Once you change all the required parameters, press key  for five seconds to come out from programming mode. If any parameter is changed, unit will restart.





18. Selecting Under Volt Tripping Value

If under voltage tripping is enabled, user can set under voltage tripping value. In L-L installation selection, its value can be set from 380 to 480 volts. In L-N installation selection, its value can be set from 195 to 204 volts. Read TRIP functionality for more details.

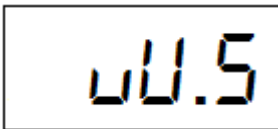
To set under voltage value, proceed as follows:

1. In the Run Mode display, press  for five seconds continuously and enter password.
2. Press  key till the following prompt is seen:





3. Press  key. Now it will show its value. Set its value by pressing  and  keys until the desired value is reached and then press  key to confirm the value. Now it will show next parameter. Once you change all the required parameters, press key  for five seconds to come out from programming mode. If any parameter is changed, unit will restart.

19. Selecting Installation



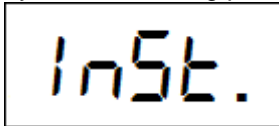

This selection must be set as per input connection of voltage measurement. If Phase to Phase is connected for voltage measurement, user has to select “L - L”. If Phase to Neutral is connected for voltage measurement, user has to select “L - n”. Control action will work depends on input voltage connection and selection of Installation.

To select the installation, proceed as follows:

1. In the Run Mode display, press  for five seconds continuously and enter password.
2. Press  key till the following prompt is seen:



The image shows a rectangular LCD display with the text "Inst." in a pixelated font. The 'I' and 'n' are lowercase, while 'S' and 't' are uppercase. A period follows the 't'.

3. Press  key. Select display prompt to “L-L” or “L-n” by pressing  and  keys and then press  key to confirm the setting. Now it will show next parameter. Once you change all the required parameters, press key  for five seconds to come out from programming mode. If any parameter is changed, unit will restart.

20. Selecting Phase compensation Value

Depends on Input connection of voltage measurement & CT connection, phase compensation value should be set for proper measurement. Below are the details of phase compensation value respect to input connection.

voltage	L1-N	L2-N	L3-N	L1-N	L2-N	L3-N	L1-N	L2-N	L3-N
CT	L1	L2	L3	L2	L3	L1	L3	L1	L2
Phase-Compensation	0	0	0	240	240	240	120	120	120

voltage	L2-L3	L3-L1	L1-L2	L2-L3	L3-L1	L1-L2	L2-L3	L3-L1	L1-L2
CT	L1	L2	L3	L2	L3	L1	L3	L1	L2
Phase-Compensation	90	90	90	330	330	330	210	210	210



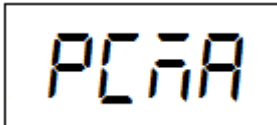

To set the value of phase compensation, proceed as follows:

1. In the Run Mode display, press  for five seconds continuously and enter password.

2. Press  key till the following prompt is seen:



PCrA

3. Press  key. Now it will show its value. Set its value by pressing  and  keys until the desired value is reached and then press  key to confirm the value. Now it will show next parameter. Once you change all the required parameters, press key  for five seconds to come out from programming mode. If any parameter is changed, unit will restart.

21. Setting Alarm for Over Compensation

If over compensation is enabled, it will work depends on the target PF and system PF value.



If target PF is set on LEAD side and if all banks are OFF and system PF is greater than target PF and system PF is LEAD for constant one minute, it will give ALARM and ALARM LED will be ON.

If target PF is set on LAG side and if all banks are OFF and system PF is LEAD for constant one minute, it will give ALARM and ALARM LED will be ON.





Once Alarm occurs and system PF goes below target PF or any bank will be ON, it will check for constant one minute and

then it will switch OFF ALARM and ALARM led. Read ALARM functionality for more details.

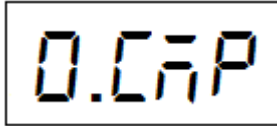
To enable or disable Alarm for over compensation, proceed as follows:

1. In the Run Mode display, press  for five seconds continuously and enter password.
2. Press  key till the following prompt is seen:





3. Press  key. Select display prompt to “YES” or “nO” by pressing  and  keys and then press  key to confirm the setting. Now it will show next parameter. Once you change all the required parameters, press key  for five seconds to come out from programming mode. If any parameter is changed, unit will restart.

22. Setting Alarm for Under Compensation





If under compensation is enabled, unit will give alarm if all banks are ON and system PF is less than target PF for constant one minute. If alarm occurs, its ALARM and ALARM led will be ON. Once Alarm occurs and system PF goes above target PF or any bank will be OFF, it will check for constant

one minute and then it will switch OFF ALARM and ALARM led. Read ALARM functionality for more details.

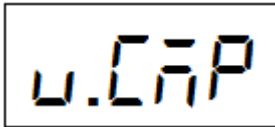
To enable or disable Alarm for under compensation, proceed as follows:

1. In the Run Mode display, press  for five seconds continuously and enter password.
2. Press  key till the following prompt is seen:





3. Press  key. Select display prompt to “YES” or “nO” by pressing  and  keys and then press  key to confirm the setting. Now it will show next parameter. Once you change all the required parameters, press key  for five seconds to come out from programming mode. If any parameter is changed, unit will restart.

23. Setting Hysteresis Value of Voltage





Hysteresis volts value can be set from 2 – 10%. Hysteresis value of volts is applicable for under and over voltage value.

To set Hysteresis volts value, proceed as follows:

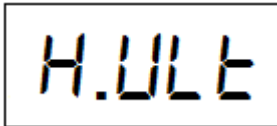
1. In the Run Mode display, press  for five seconds continuously and enter password.

2. Press  key till the following prompt is seen:





3. Press  key. Now it will show its value. Set its value by pressing  and  keys until the desired value is reached and then press  key to confirm the value. Now it will show next parameter. Once you change all the required parameters, press key  for five seconds to come out from programming mode. If any parameter is changed, unit will restart.









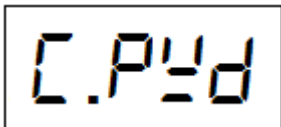





24. Setting New Password

User can change password using this parameter. Once you set new password, you can enter into programming mode using this password.

To set new password, proceed as follows.

1. In the Run Mode display, press  for five seconds continuously and enter password.
2. Press  key till the following prompt is seen:





3. Press  key. Its 1st digit will start blinking. Set its value between 0 - 9 by pressing  and  keys and press . Now its 2nd digit will start blinking. Set its value between 0 - 9 by pressing  and  keys and press . Now its 3rd digit will start blinking. Set its value between 0 - 9 by pressing  and  keys and press . Now its 4th digit will start blinking. Set its value between 0 - 9 by pressing  and  keys and press . Now new password is properly saved. Now it will show next parameter. Once you change all the required parameters, press key  for five seconds to come out from programming mode. If any parameter is changed, unit will restart.

25. Setting Manual banks (Manual mode only)

This parameter is applicable only if Manual mode of control action is selected. User can manually switch ON/OFF all banks one by one.

To set banks ON or OFF, proceed as follows.

1. In the Run Mode display, press  for five seconds continuously and enter password.

2. Press  key till the following prompt is seen:

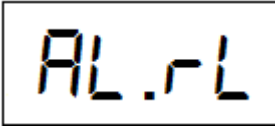





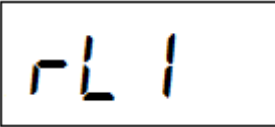

A rectangular LCD display showing the text "AL.rL" in a pixelated font. The characters are black on a white background.

3. Press  key. Now it will show below prompt.



A rectangular LCD display showing the text "rL 1" in a pixelated font. The characters are black on a white background.

4. Now if you want to switch ON/OFF bank number one, press  key. Then select "On" or "OFF" by pressing  and  and then press . Its respective bank number will work according to selection. User can reach to desired bank value by pressing  and  key and follow the above mentioned procedure to switch ON/OFF respective bank.

NOTE: Wait for some time to discharge capacitors while switch ON/OFF banks.

Run Mode

Below are the details of Run mode functionality and display pages.

Screen Display

In Run mode, only svstem PF will be displayed as below.

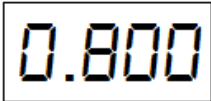
 For Lag

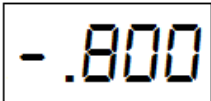
 For Lead

ALARM Functionality

Unit will give ALARM and ALARM led will be ON if under or over compensation is occurred. For example if user has enabled over and under compensation, it will work as described below.

Under Compensation

If all banks are ON and system PF is less than target PF for constant one minute, it will give ALARM and ALARM led will be ON.

Once ALARM occurs, press  key and it will display below page for 3 seconds and return to PF value page.

AUTO ○
ALARM ●

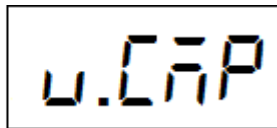

Once Alarm occurs and system PF goes above target PF or any bank will be OFF, it will check for constant one minute and then it will switch OFF ALARM and ALARM led.

Over Compensation

If target PF is set on LEAD side and if all banks are OFF and system PF is greater than target PF and system PF is LEAD for constant one minute, it will give ALARM and ALARM LED will be ON.

If target PF is set on LAG side and if all banks are OFF and system PF is LEAD for constant one minute, it will give ALARM and ALARM LED will be ON.

Once ALARM occurs, press  key and it will display below page for 3 seconds and return to PF value page.

AUTO ○
ALARM ●

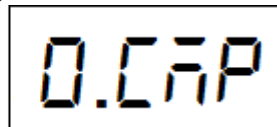

Once Alarm occurs and system PF goes below target PF or any bank will be ON, it will check for constant one minute and then it will switch OFF ALARM and ALARM led.

TRIP Functionality

If under or over voltage is enabled and its input voltage is out of range of its selected value for constant one minute, unit will give

ALARM and ALARM led will be ON. Also it will switch OFF all the banks. For example if user has enabled over and under voltage tripping, it will work as described below.

Under voltage trip

For example if user has selected under voltage value to 204 volts and input voltage of unit is less than this value for constant one minute, it will give ALARM and ALARM led will be ON. It will also switch OFF all the banks and it will display below page instead of PF value page.

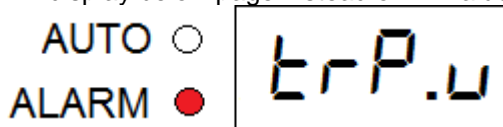

It will remain in this condition until input voltage is greater than addition of selected under voltage value and percentage of hysteresis voltage for constant one minute.

Over voltage trip

If user has selected over voltage value to 264 volts and input voltage of unit is greater than this value for constant one minute, it will give ALARM and ALARM led will be ON. It will also switch OFF all the banks and it will display below instead of PF value page.

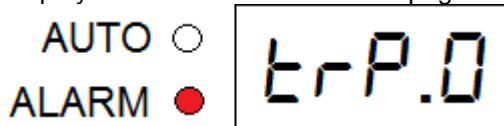

It will remain in this condition until input voltage is less than subtraction of selected over voltage value and percentage of hysteresis voltage for constant one minute.

Manual/Auto Mode

PFC1729 has in-built Auto Mode and Manual Mode of operation. The default mode of operation is Auto Mode in which all relays take control action according to the nature of load in the system. In case the relay's automatic control action needs to be overridden and the user desires to operate the capacitor stages manually, the relay can be taken in the manual mode by selecting manual in control action parameter. If unit is in manual mode, its AUTO led will be OFF.

On taking the relay from Auto to Manual mode, it will switch off all the capacitor banks and will not take only control action. User can manually switch ON/OFF banks as described above in setting manual banks.

Control Outputs

The relays are protected by snubbers against fast voltage transients which occur when inductive loads are switched off and therefore, the following points should be taken care when using these relay contacts:

- Use 230V AC coils only in the contactors. DO NOT use 440V AC coils.
- DO NOT switch small loads like electronic Hooters, small relays with 230V AC coils etc., directly from the relay contact of PFC1729. If done so, the small leakage current from the snubbers will not allow these loads to be switched off fully. The electronic hooters thus will give a low hum continuously, and the small relays will switch on but not switch off. Use these relay contacts to switch an Auxiliary contactor and put the load on the contactor contacts.

For correct operation, various points in the system need attention and unless these are correctly set up, proper operation cannot be expected.

(A) Trouble Shooting

The **PFC1729** is robust electronic equipment and must be handled with all the care merited by it. It is quite rugged and will withstand a few hard knocks, but this cannot make up for the deficiency in system design.

Repairs at site are not recommended because at most this can only be a patch work, and sustained reliability is difficult to achieve with a site repaired Relay. This section on Troubleshooting therefore deals with fault finding in the system and to establish whether the Relay is defective or

whether it is a system problem. If the fault is seen to lie entirely with the Relay, it will have to be sent to factory for repairs.

System faults can be classified into three categories:

- Those related to the basic configuration of the system.
- Those related to the errors and mistakes in the implementation of the system design.
- Those related to the faults in the actual equipment.

The most common faults are:

External Manual Control not implemented properly

Here many designers provide a ‘Starter-relay’ configuration for the manual control, and just bring the connection from the relay contact to the contactor.

There are two problems with this:

- I. Timing function is not provided from Manual control.
- ii. The scheme does not work in Auto mode. The remedy is to examine the drawings and make changes at site. The temporary remedy is to change the relay mode to Manual, and use the panel manually. The better alternative is to change the control wiring to incorporate suitable isolating contacts, timers etc. to make a proper system.

CT of the Capacitor Panel itself connected to the Relay

In this case obviously the Relay does not read the power factor of the system. There is no current through the Relay when capacitors are off. If you force one of the capacitors on, it may cause an indication of full Lead (if the current taken by the capacitor is sufficiently high). If the Relay is in Auto mode, it will switch off the capacitor immediately, and nothing further will happen.

b. Faults Related to the actual site conditions:

These faults occur when the actual site conditions are different from those assumed by the designer of the system. These faults relate to the location of the load feeders on the busbar, buscouplers, and connections from transformers etc. ***The locations of the CTs are the most important factor as far as the Relay is concerned.***

Another problem frequently encountered is that of insufficient load on the power system. This might occur because the Plant has not been commissioned fully, or because the system allows for future expansion. In either case the actual current through the CT is very low compared to the rating of the CT.

In such conditions, the relay, (specially, if there are no small banks in the capacitor panel) will not take any control action at all. However, the transformer losses will cause the monthly average PF to show up as

very poor. The remedy is to connect a small bank directly (independent of the automatic control scheme) for compensating transformer losses. These relate to the defects in the connected equipments. Again an exhaustive list is beyond the scope of this document. A few are listed below:

Blown fuses, shorted CT, shorted voltage connections, switches that do not make contact, open connections etc. Check everything - before, during and after commissioning and you will be rewarded with a finely tuned system which will give you years of trouble-free service.

(B) Trouble Shooting Guide

- 1. *Relay is dead.*** Check that the specified voltages are available at the voltage terminals of the Relay. Do not check with a neon tester. Use a multi-meter and check physically the voltages available. If the voltage is available and the Relay is dead, the Relay in all probability is defective. Please send it back for repairs.
- 2. *Relay does not indicate expected power factor.*** Your wiring is wrong. Either the wrong phase is coming to the Relay or the location of the main CT is not correct. It may be on the wrong phase or mounted such that the total load current and the capacitor current is not flowing through it.

3. Relay switches the capacitors on, but the power factor does not improve

The source of this fault could be:

- a. The CT is located only on the Load bus, and capacitor current is not passing through the CT. Change the location of the CT to the true main Incomer.
- b. The capacitors are all defective. This seemingly unlikely fault has occurred at many sites. Measure the current in each lead of each capacitor as it switches on, to check. This would also reveal if all the fuses of all the capacitors have blown.

4. Relay switches on all the capacitors, the power factor improves, but does not reach the set value. At the extreme is the possibility that the total installed KVAR is too low. In this case, the Relay switches on all the capacitors but the power factor does not improve to the set value. Check if the capacitors are healthy. Remedy is to add capacitors and add stages. This may need total reconfiguration of the panel wiring.

5. Relay switches on the contactors but does not switch them off, though indication on the Relay is correct. The External Manual control is not configured correctly. The contactors are latching up through their holding contacts. Extensive rewiring is required to

remedy this fault. This is also possible if 440 VAC coils have been used.

6. *Relay is on but PF meter indicates 1.0 always.* The current through the Relay is inadequate.

P.O No. : _____

Customer : _____

Sr. No. : _____

Routine and function tests conducted to relevant standards and our Specifications/Literature/O & M Manual.

Traceability: tested against "MTE" Standard Model PRS400.3 having basic accuracy of 0.02%, traceable upto International Standards derived using appropriate ratio techniques.

Result of Test : _____

Remarks : _____

Test engineer : _____

Date : _____